

Build a Rowing-Sailing Dory

By Bob Whittier



ONE DAY while hiking in the woods of southeastern Massachusetts with my young sons, we came to a cranberry bog reservoir and spotted a boatlike shape in its depths. We pulled it ashore and found it to be the battered remains of a little dory. A real old-timer, with frames made of natural crooks of apple wood, pine planking and clinched boat nails. Easily 50 to 75 years old and obviously the product of a master dory-builder!

She was too far gone to rebuild, but we covered her bottom with polyethylene plastic to make her float long enough to try out. And as we had anticipated from the looks of her, she proved to be one sweet little rower. At the same time, she was wide enough across the bottom to have none of the "crankiness" for which dories are both famed and feared.

Using her as a guide, we built a new dory. This reincarnation is just as sweet a rower—and not as fussy to build as

you might suppose. Build her as a utility boat, as a tender, as a silent sneak-up-on-'em fishing skiff, as a trainer and fun-boat for the kids—or just as a conversation piece. The first time you take her out you'll be flabbergasted at how easily she darts along with light pulls on the oars.

Of course, she can also be sculled—propelled by a single oar stuck through a hole in the transom and wiggled back and forth with a certain twist of the wrist. This gives a narrow rig that can sneak between moored boats and dock piles like an eel.

And as a bonus, she can be sailed; she's just the right size and width to do well with the rig from a sailing surfboard or dinghy—say something between 45 and 65 sq. ft. area. If you don't care to sail in a bathing suit in April or October, pop your sailing board's rig into this dory and sail in dry comfort until warm weather comes!

We've modernized construction a

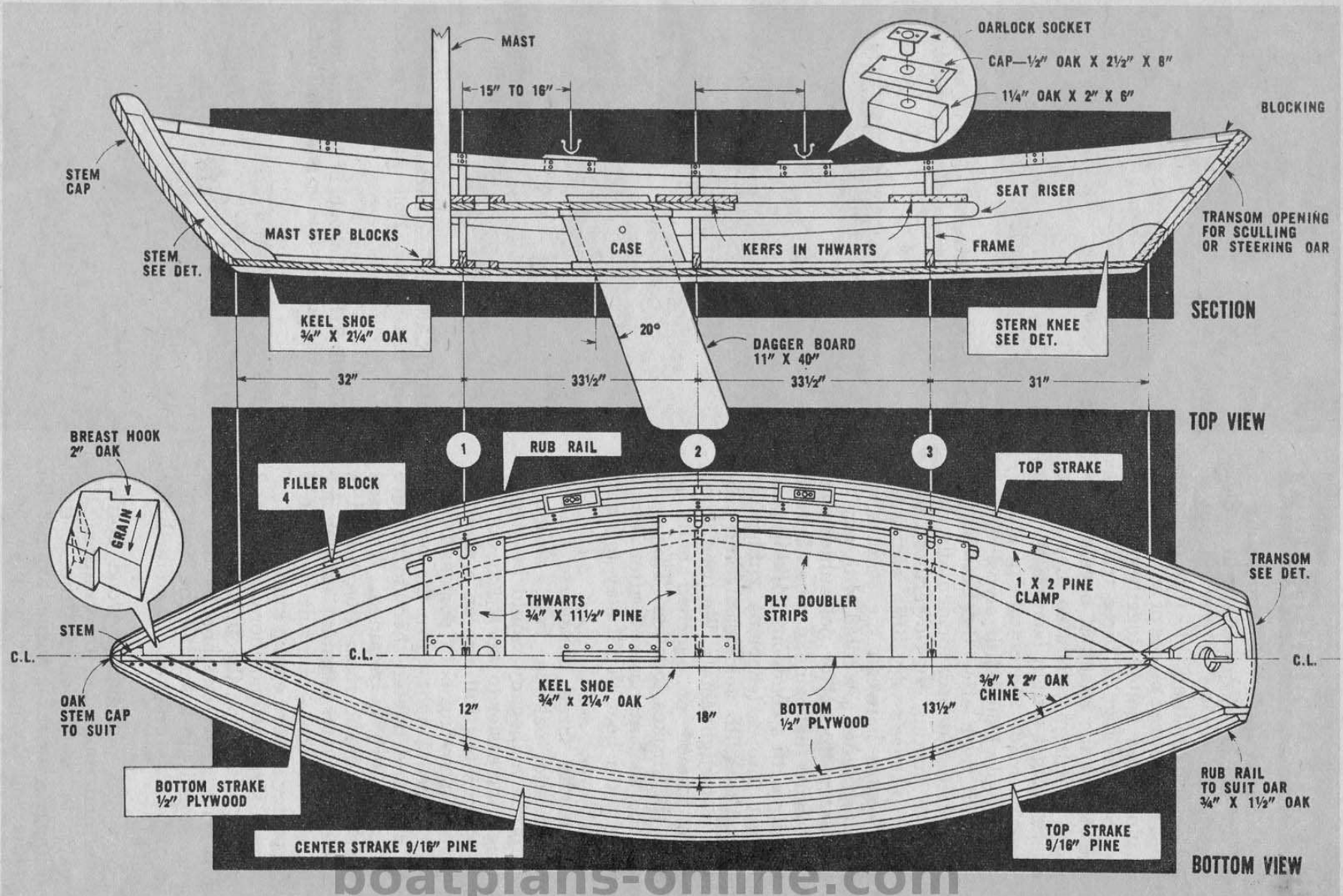

Rowing-Sailing Dory

little. Natural apple wood crooks are as hard to find as buggy whips in a discount house, so we've worked out a close approximation of the original frames using three pieces of sawn white oak glued and bolted together. You'd have to build two or three traditional dories to get the knack of beveling the bottom boards just right so they won't leak. So, to get a tight boat on the first try, we've made the bottom of sturdy 1/2-in. five-ply Douglas fir plywood. The pieces left over after the bottom has been gotten out are, incidentally, just right for making the lowermost side strakes so there's very little waste.

The seams between the strakes on this dory's sides are filled with any of the modern thiokol or polysulfide marine sealants that come in tubes. Spread on easily with a common caulking gun, they set into a tenacious rubberlike material that fills voids easily and produces watertight joints. We used wood screws instead of clinched nails to fasten the strakes together. They hold until the sealant has set, after which you've got a boat that'll stay together dependably.

Make the three transverse frames first. White oak is best, although Philippine mahogany would be strong enough and easier to work. Lay out the frame drawings full size on a sheet of plywood, showing both port and starboard sides. Weight down the parts as you drill and tighten them to be sure that symmetry is retained. We used water-mix plastic resin glue, which is thoroughly water-resistant enough for this sort of boat—but suit yourself if you prefer a more exotic kind.

Use a straight and thoroughly dry 2 by 6-in. plank for the jig's backbone; start with a wet one and by the time you're ready to assemble the boat it'll be almost as crooked as an arthritic snake.

Now get out the plywood bottom panel and rough out the transom. It's smart to double-check the bottom widths of your three frames against the widths you lay out on the plywood—



STEM, FRAMES, transom set up on building jig. Make sure 2 by 6-in. plank is well dried.

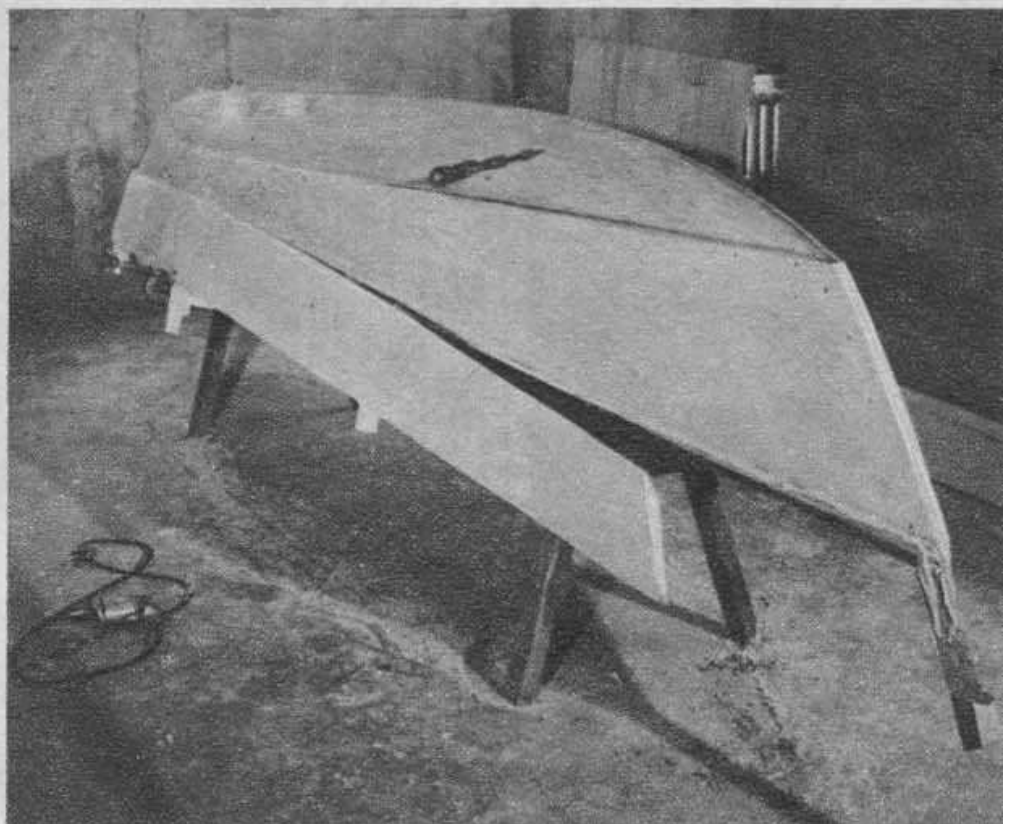

SOLID PLANK second strake laps over plywood first strake. Note bevels, sealant.

SECOND STRAKE should fit flush into frame notch. Check, then true up with hand plane.



leave say 1/4-in. surplus to allow for planing down later. But go rather easy at the widest part of the bottom panel as you must leave the trimmed pieces wide enough for the two lowermost strakes!

Make stem and transom knee and also saw out the transom. This is a hard component to depict clearly on plans because of its extreme rake and the way the sides angle in rather sharply to join it. However, you go by the outside dimensions; make the whole thing an inch or more oversize so that you can plane it down to those dimensions while still getting the angles necessary for the sides to lay onto it snugly. To save hunt-

ing down a piece of 1 3/4-in. oak or mahogany plank for the stem, it's quite all right to laminate two 7/8-in. boards with waterproof glue.

Lay the three frames into their notches on the backbone. Attach the stem and [Continued on page 120]

LARGE SCALE PLANS

including additional photos and details of centerboard case construction are available for \$3. Send check or money order to: MI Plans Service, Fawcett Building, Greenwich, Conn. 06830. Specify Plan SD-4-68.

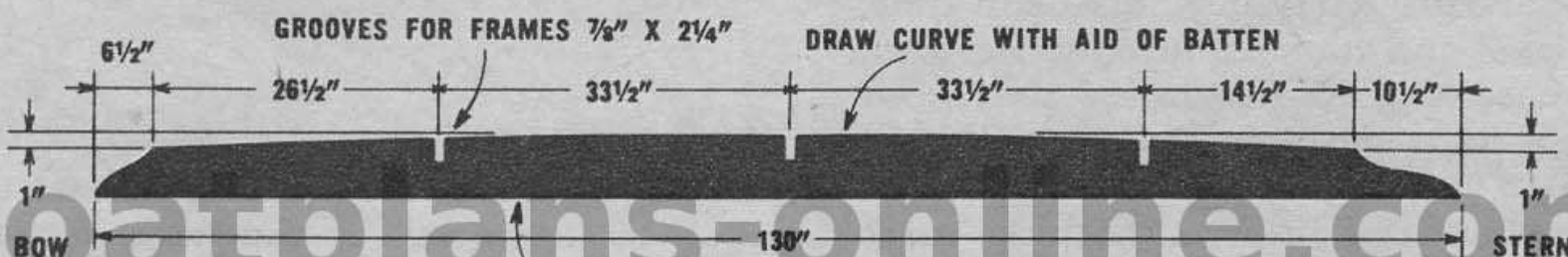
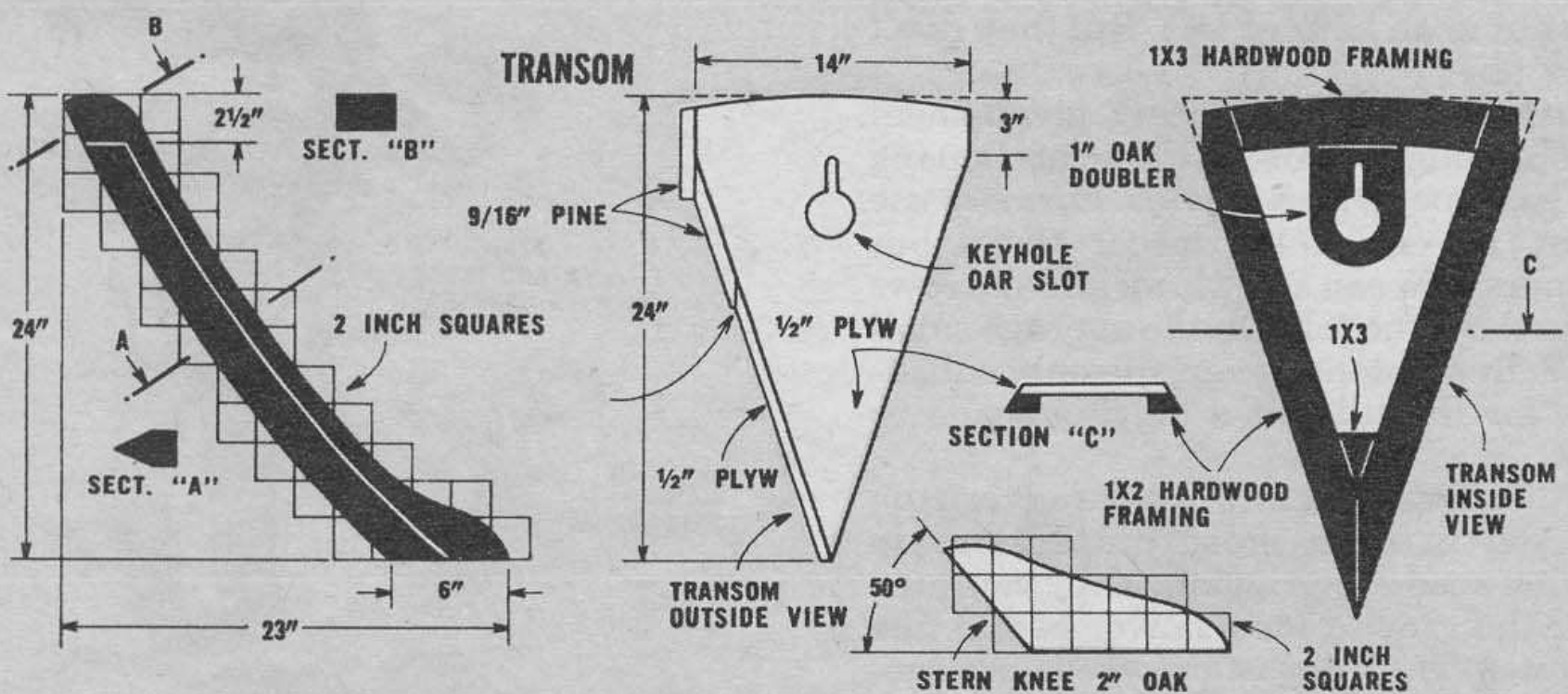
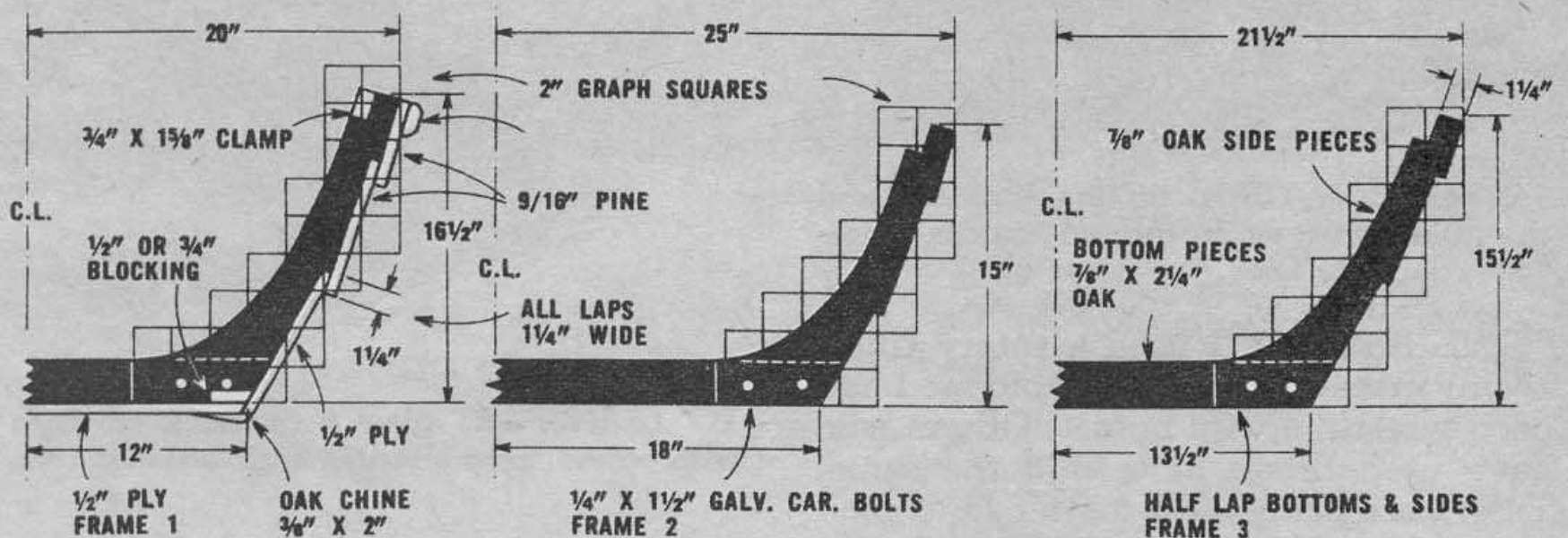

BACK BONE OF JIG 2X6 STRAIGHT DRY PLANK

Rowing Sailing Dory

[Continued from page 93]

transom temporarily with screws and make sure they are plumb and square. Lay the bottom plywood in place. Numbers 1 and 3 frames will need a little bevel planed onto their bottoms to fit snugly against the plywood due to the slight rocker in the dory's bottom.

Using a long, limber batten as a guide, rasp the outer faces of the side members of Nos. 1 and 3 frames to an angle so the planking will butt snug against the frames. Using a yardstick as a guide, plane down the edges of the bottom plywood to the same angle as the flare of the sides.

Now to deterrorize the process of lapstraking! Take one of the long "scraps" left after getting out the bottom panel and lay it onto the side of the boat. The straight edges of these scraps, not the curved edges you sawed in getting out the bottom, go uppermost—remembering here that the boat is upside down. Due to the flare in the sides, as you bend these lengths onto the boat you will find that those straight edges develop an appreciable curve and will fit right into the first "steps" in the outside edges of the side frames. If your luck tends to be bad, at worst you might have to cut down or shim up one of these steps a little. Put one of these strakes on temporarily, then, with a few screws.

With a pencil held flat against the bottom, make a line on the inside of this strake, remove it and saw along the line

leaving just a little surplus that can be planed off later. Do the same on the other side.

You'll now have several plywood scraps from which it'll be possible to get out the doubler strips that go around the edge of the bottom to facilitate gluing and screwing the sides and bottom together. Glue and screw these strips on, butting them against the three frames. Leave enough "overhang" to allow them to be planed to the same bevel that has been put on the bottom edges.

One at a time, clamp on the boards that form the second strakes, lapping them at least 1¼-in. over the lower plywood strakes. Using the edges of the bottom strakes as guides, from underneath the boat mark a long, sweeping line on the inside of each of the second strakes. Also while underneath, make pencil marks on the boards at the points where they lie against the "steps" in the side frames.

When the boards are removed there'll be one solid line and one "dotted line" that can be made full and sweeping with a limber batten held down on the frame

marks. Bandsaw the strakes to shape. Clamp port and starboard ones together and plane their edges so both are just alike. And there are your strakes, complete with sweeping curves and taper and with very little sweat! Repeat the process for the top row. Set a try square for 1¼-in. and draw lines on the strakes to serve as guides for planing down the areas where the strakes overlap.

You can use either hard-setting glue or non-hardening sealant at the joints between bottom plywood and the frames, and between the bottom and the side strakes. Mostly, 1¼-in. No. 8 flat head brass wood screws are used, except near the ends of the strakes where there's more bevel and 1-in. or even ¾-in. screws are better.

Seat support rails are next, after the boat is turned over, and there's a trick or two here. Note that they flare out a lot where they are attached to the frames. If they were made straight, it'd be murder and then some to try to force them to be "straight" as seen in the side view. So, get some scrap ¼-in. plywood perhaps 8-in. wide and a little longer than the rails.

[Continued on page 124]

Rowing Sailing Dory

[Continued from page 121]

Press it into place and attach temporarily to the inside of Frame 2.

Find a box or something 9-in. high and set it inside the dory. Rest a straight-edge on the box and slide this rig back and forth to mark the plywood. When the plywood is taken out it will have a sweeping curve marked on it. Use this as a guide to bandsaw two seat rails out of a wide board. These rails will have about three inches of bow in them and when in place they will be "straight" as seen from the side.

For sailing, we made two holes in the forward thwart and fitted two mast steps on the bottom so the mast could be shifted if necessary to get best trim. Hardwood blocks about 6-in. by 6-in. with appropriate holes in them are glued and bolted to the bottom to serve as mast steps.

If your mast is "bendy," a removable cross brace set between the top ends of Frame 1 may be needed to hold it upright, as the seat, made for rowing, may be a little low to support such a mast firmly.

It's hard to come up with a neat and handy rudder on a dory's raked transom so, all things considered, an oar seems the best method of steering. The oar port in the transom is "keyhole" shaped so the oar can be run through from inboard. A steering oar is advantageous in close quarters since with it, the boat's stern can be "rowed" to come about quickly. •